

Machine Tools LINE-UP

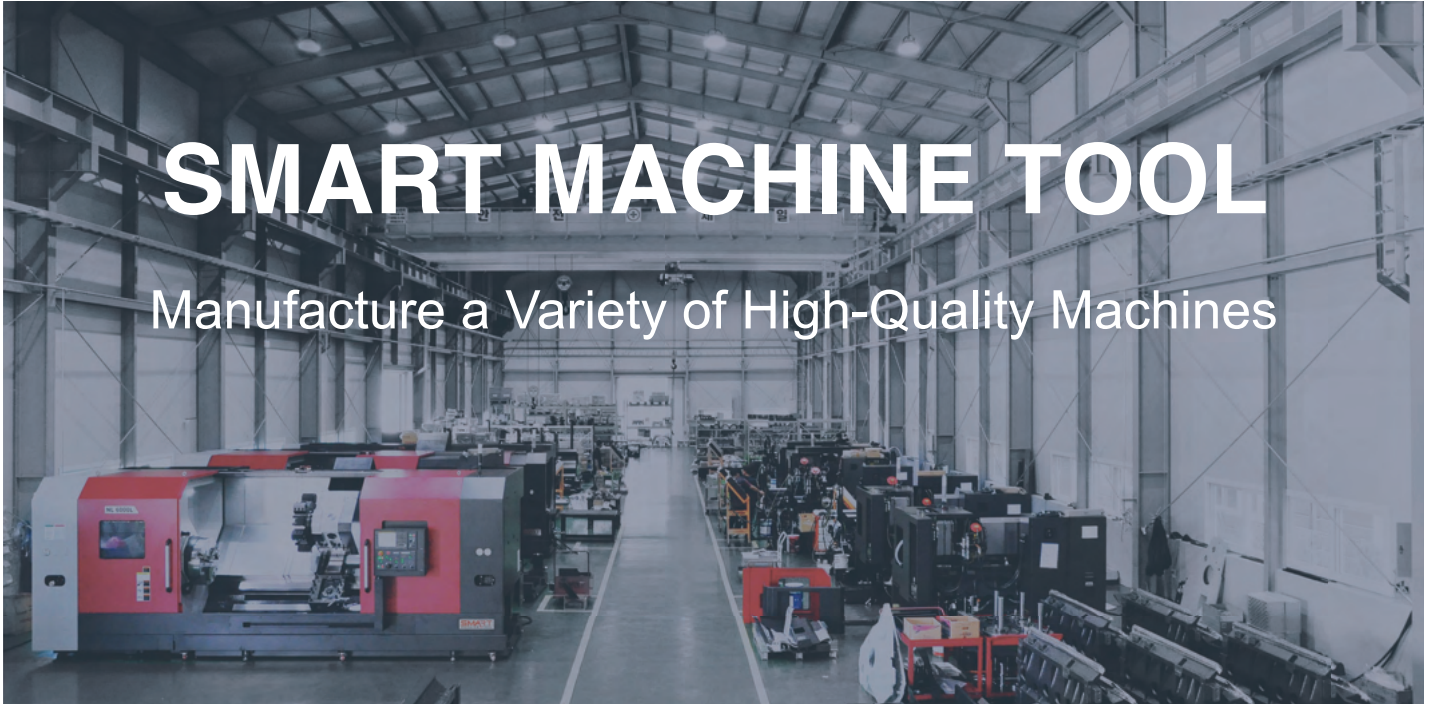



SMART MACHINE TOOL

Manufacture a Variety of High-Quality Machines

2

Smart Machine Tool produces machine tools based on the team's knowledge of product design, engineering and understanding what the market needs.





Smart Machine Tool Korea

With over 100 years of combined experience in the machine tool industry, Jong B. Won, Jong C. Kim, and Jong W. Shin were the original members of Samsung Machine Tools before starting Smart Machine Tool Korea. They are shareholders of Smart Machine Tool Korea and serve as CEO, the Head of Manufacturing, and the Head of Engineering and Design, respectively. Brian Whang Started at Hyundai in 1993 and has spent the past 20 years in sales and finance at Dynamic International. He is a lawyer and CPA and serves as CFO for Smart Machine Tool Korea. Richard Layo, the owner of Dynamic International, started a Wisconsin based dealership in 1986, and started importing high-end CNC machine tools in 1999 from Japan, Korea, Taiwan and Smart Machine tool Korea and serves as Chairman.



Smart Machine Construction

Headstock

Radiator fan-like pin tube rib design dissipates heat generated by axis movements, maintaining minimum thermal expansion



Pre-Tension and Double Anchored Ballscrews

All axes ballscrews are pre-tensioned, heat treated and fixed by doubled anchors on both ends, providing ultimate rigidity and minimal thermal growth.



Spindle

Double row cylindrical roller bearings and angular thrust bearing, ensure high rigidity for heavy cutting and excellent surface finishes.

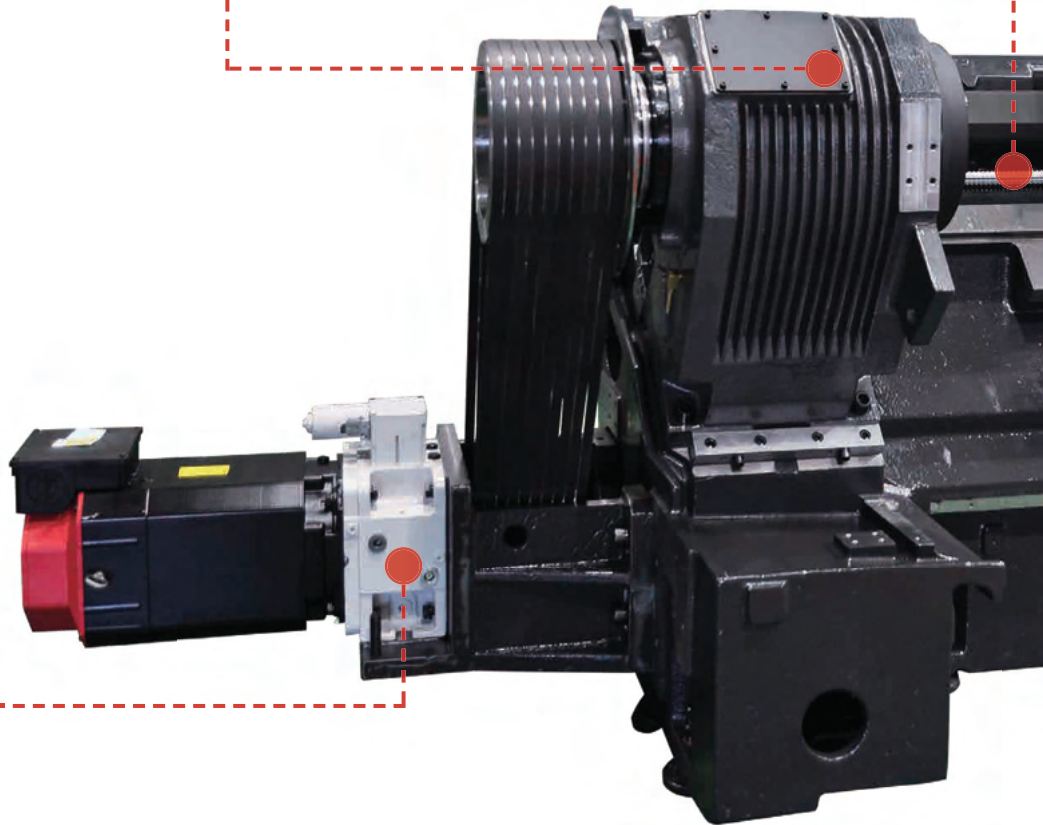
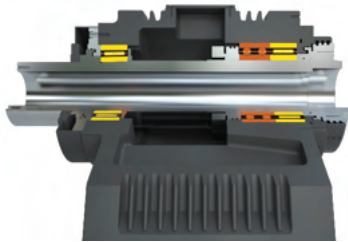

Gearbox

NL 2500, 3000, 4000, 5000, 6000 are equipped with two-speed in-line gearbox provide machining stability and increase torque at low speed.



NL 2500, 3000 gearbox



NL 4000, 5000, 6000 gearbox

Rigid 45 Degree Slant Bed

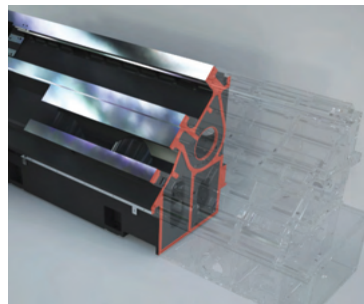

The 45 degree slant torque tube design bed and wide guide slide ways
Easy access to the workpiece and superb chip discharge.

12-Station Turret

Large diameter 3-piece Curvic coupling for excellent rigidity and extended tool life.

High torque AC servo motor driven for fast indexing time and excellent positioning and repeatability.

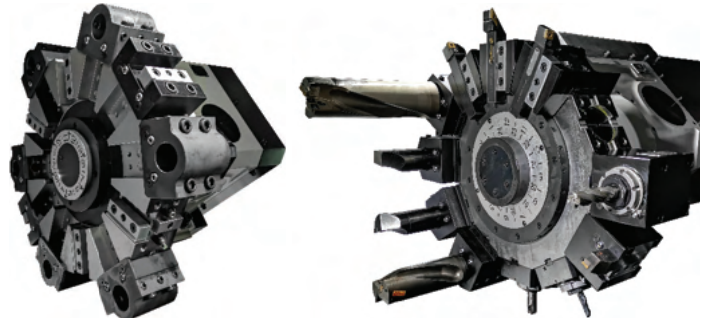

Programmable Tailstock Body & Quill

Wide-spaced guideways and heavy-duty tailstock body design ensure machining rigidity, and built in spindle quill design ensures higher rigidity.



Hexahedral Slide Ways (X-axis)

Wide boxways, machined from one-piece casting, promote heavy-duty machining.

Induction hardened and precision ground ways ensure accurate machining for extended periods of time.

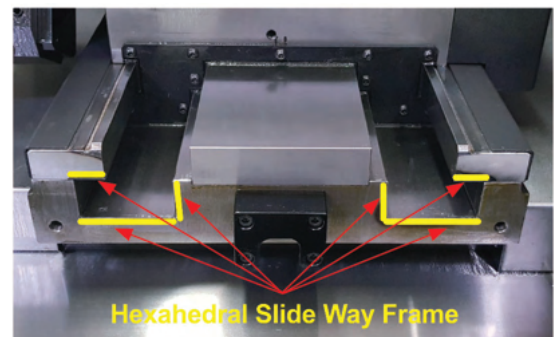

Hand Scraping

Precise hand scraping on all the contact surface to the bed ensures long-lasting machining accuracy and minimal surface wears.



NL 1500 | 2000 6", 8", 10" Chuck / A2-5, A2-6, A2-8 spindle nose

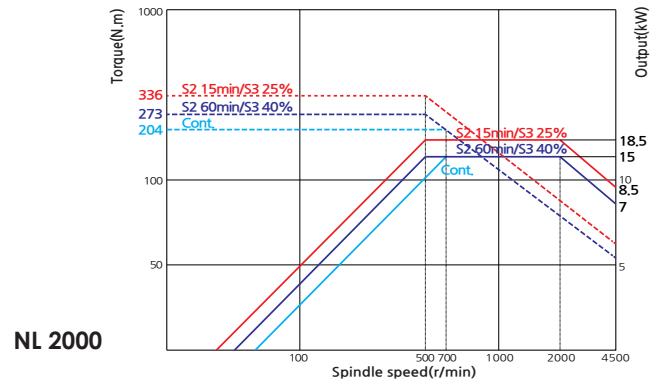
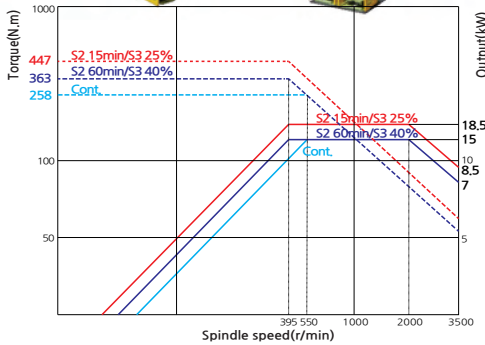
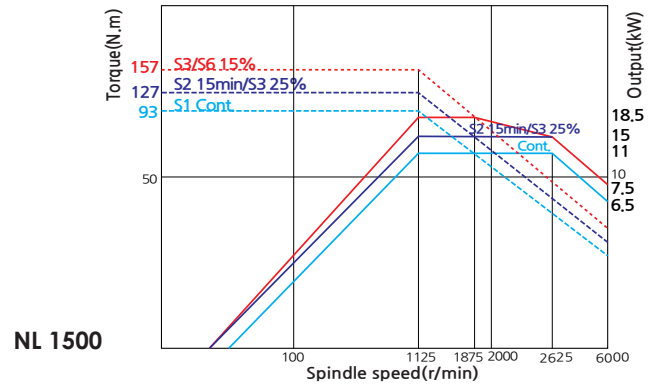

6

Turret Head Interference Unit: mm(inch)

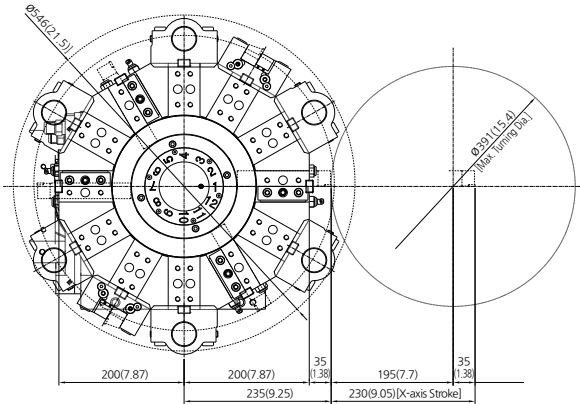

NL 2000

Work Range Unit: mm(inch)

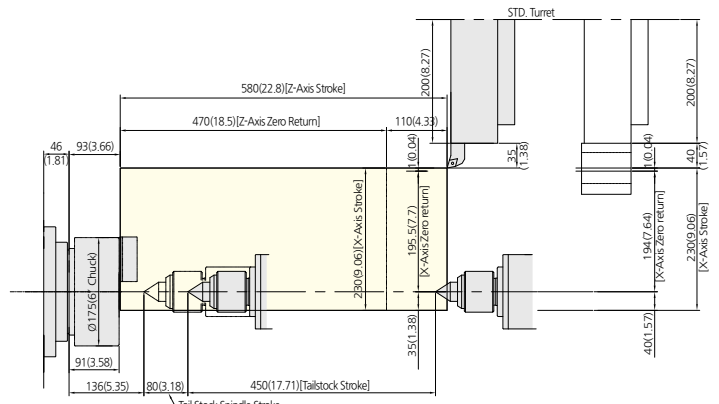

NL 2000

Machine Dimensions Unit: mm(inch)

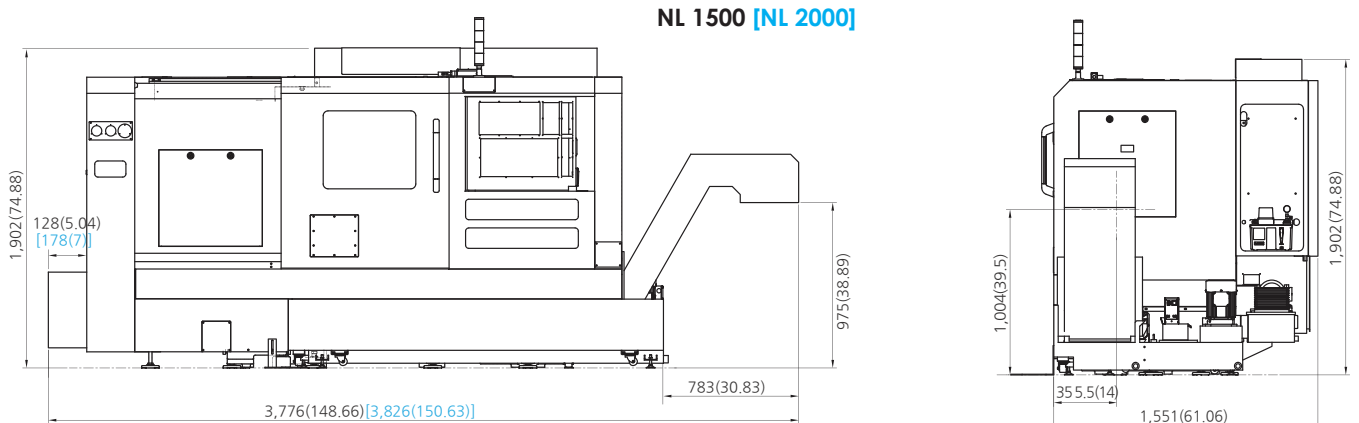

NL 1500 [NL 2000]

Machine Specifications

DESCRIPTION		NL 1500	NL 1500M	NL 2000	NL 2000M	NL 2000B	NL 2000BM
CAPACITY	Swing over the bed mm(inch)	570(22.44)					
	Swing over the cross slide mm(inch)	370(14.57)					
	Max. machining diameter mm(inch)	391(15.39)	381(15.0)	391(15.39)	381(15.0)	391(15.39)	381(15.0)
	Max. machining length mm(inch)	560(22.05)	540(21.26)	560(22.05)	540(21.26)	550(21.65)	540(21.26)
	Chuck size Inch	6		8		10	
	Bar working dia. mm(inch)	51(2.01)		65(2.56)		81(3.19)	
SPINDLE	Spindle speed rpm	6,000		4,500		3,500	
	Spindle motor (Cont./Max.) kW(Hp)	11/18.5(15/25)		15/18.5(20/25)		15/18.5(20/25)	
	Spindle nose ASA	A2-5		A2-6		A2-8	
	Spindle torque (Max.) N.m(ft.lbs)	157(115.8)		336(247.8)		447(329.7)	
	Spindle through hole dia. mm(inch)	61(2.4)		76(2.99)		91(3.58)	
TRAVEL	Rapid traverse (X/Z) m/min(ipm)	24/30(945/1,181)					
	X-axis travel mm(inch)	230(9.06)					
	Z-axis travel	580(22.83)	560(22.05)	580(22.83)	560(22.05)	580(22.83)	560(22.05)
	Feed motor (X/Z) kW(hp)	1.8/3(2.4/4)	3/3(4/4)	1.8/3(2.4/4)	3/3(4/4)	1.8/3(2.4/4)	3/3(4/4)
TURRET	Number of tool stations st.	12	12(24)	12	12(24)	12	12(24)
	OD tool size mm(inch)	□25(1)					
	Max. boring bar size mm(inch)	Ø40(1.5)				Ø50(2)	Ø40(1.5)
	Indexing time sec	0.15/Step					
	Milling tool holder type	-	BMT55	-	BMT55	-	BMT55
	Max. rotary tool spindle speed rpm	-	5,000	-	5,000	-	5,000
	Rotary tool motor power kW(hp)	-	3.7/5.5(5/7.4)	-	3.7/5.5(5/7.4)	-	3.7/5.5(5/7.4)
TAILSTOCK	Tailstock travel mm(inch)	450(17.72)					
	Quill diameter mm(inch)	80(3.15)					
	Quill travel mm(inch)	80(3.15)					
	Taper of tailstock spindle	MT#4 Live center					
BED TYPE	45° Slant						
ELECTRIC POWER SUPPLY kVA	31						
REQUIRED FLOOR SPACE mm(inch)	3,140x1,560(124x62)						
MACHINE WEIGHT kg(lbs)	3,800(8,378)			3,900(8,598)			
CONTROLLER	Fanuc Oi-TF						

- Figures in inches are converted from metric measurements.
- Design and specifications are subject to change without notice.

Standard Accessories

- Coolant unit 10bar (140PSI)
- Work light (LED lamp)
- Splash guard with side coolant tank
- Tool/Work box
- Hyd. Hollow chuck
- Leveling blocks
- Chuck clamp foot switch
- Chuck clamp confirmation
- Manual/Part list
- Door interlock
- Tailstock in-out foot switch

Optional Accessories

- Chip conveyor
- Dual pressure chucking
- Auto door
- Oil skimmer
- Part catcher
- Coolant gun
- Tool presetter

NL 2500 | 3000 10", 12" Chuck / A2-8, A2-11 spindle nose



NL 3000

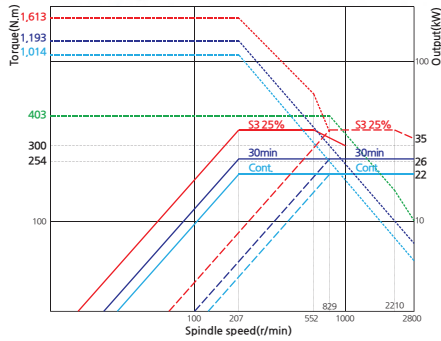

NL 2500/500

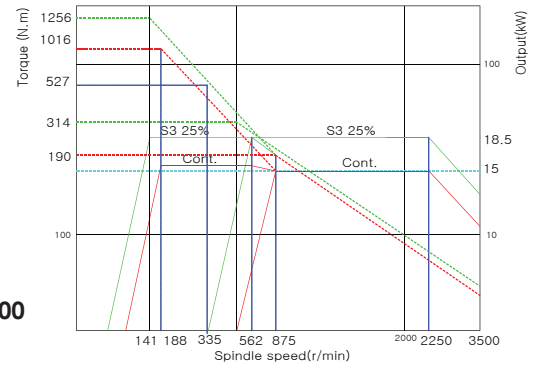

NL 2500/750

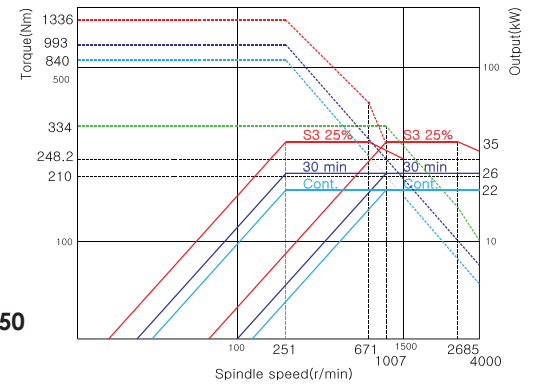

Turret Head Interference

Unit: mm(inch)

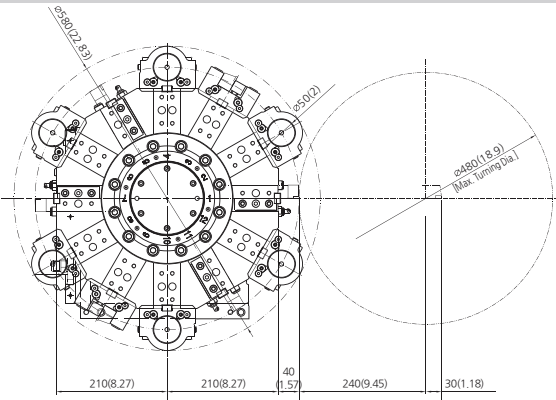

NL 2500 | NL 3000

Work Range

Unit: mm(inch)

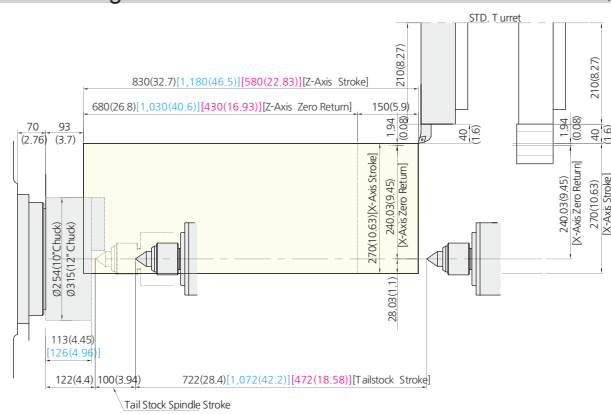

NL 2500/750 | NL3000B/750 [NL 3000B/1100] [NL 2500/500]

Machine Dimensions

Unit: mm(inch)

NL 2500/750 | NL3000B/750 [NL 3000B/1100] [NL 2500/500]

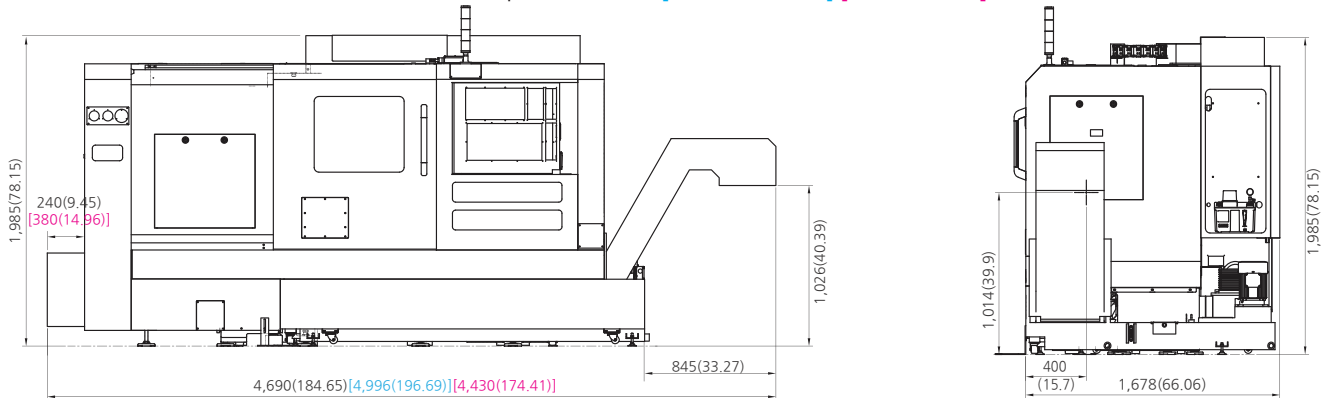

Machine Specifications

DESCRIPTION			NL 2500/750 [NL 2500/500]	NL 2500M/750 [NL 2500M/500]	NL 3000B/750 [NL 3000B/1100]	NL 3000BM/750 [NL 3000BM/1100]
CAPACITY	Swing over the bed	mm(inch)	700(27.56)			
	Swing over the cross slide	mm(inch)	510(20.08)			
	Max. machining diameter	mm(inch)	480(18.9)	450(17.72)	480(18.9)	450(17.72)
	Max. machining length	mm(inch)	750(29.53) [530(20.87)]	700(27.56) [480(18.9)]	750(29.53) [1,100(43.31)]	700(27.56) [1,050(41.34)]
	Chuck size	Inch	10		12	
	Bar working dia.	mm(inch)	81(3.19)		102(4.02)	
SPINDLE	Spindle speed	rpm	4,000 [3,500]		2,800	
	Spindle motor (Cont./Max.)	kW(Hp)	22/35(29.5/47) [15/18.5(20/25)]		22/35(29.5/47)	
	Spindle nose	ASA	A2-8		A2-11	
	Spindle torque (Max.)	N.m(ft.lbs)	1,336(985.4) [1,256(926.4)]		1,613(1,189.7)	
	Spindle through hole dia.	mm(inch)	91(3.58)		115(4.53)	
TRAVEL	Rapid traverse (X/Z)	m/min(ipm)	24/30(945/1,181)			
	X-axis travel	mm(inch)	270(10.63)			
	Z-axis travel	mm(inch)	830(32.68) [580(22.83)]	770(30.31) [520(20.47)]	830(32.68) [1,180(46.46)]	770(30.31) [1,120(44.09)]
	Feed motor (X/Z)	kW(hp)	4/4(5.4/5.4)			
TURRET	Number of tool stations	st.	12	12(24)	12	12(24)
	OD tool size	mm(inch)	□25(1)			
	Max. boring bar size	mm(inch)	Ø50(2)			
	Indexing time	sec	0.2/Step			
	Milling tool holder type	-	-	BMT65	-	BMT65
	Max. rotary tool spindle speed	rpm	-	5,000	-	5,000
	Rotary tool motor power	kW(hp)	-	3.7/5.5/7.5(5/7.4/10)	-	3.7/5.5/7.5(5/7.4/10)
TAILSTOCK	Tailstock travel	mm(inch)	722(28.43) [472(18.58)]	722(28.43) [1,072(42.2)]		
	Quill diameter	mm(inch)	110(4.33)			
	Quill travel	mm(inch)	100(3.94)			
	Taper of tailstock spindle	-	MT#4 (Built-in)			
BED TYPE		-	45° Slant			
ELECTRIC POWER SUPPLY		kVA	40 [35]	40 [35]	40	40
REQUIRED FLOOR SPACE		mm(inch)	3,708x1,727(146x68) [3,208x1,778(126.3x70)]		3,708x1,727(146x68) [4,013x1,727(158x68)]	
MACHINE WEIGHT		kg(lbs)	5,700(12,566) [4,700(10,361)]		5,700(12,566) [6,900(15,211)]	
CONTROLLER		-	Fanuc 0i-TF			

- Figures in inches are converted from metric measurements.
- Design and specifications are subject to change without notice.

Standard Accessories

- Coolant unit 10bar (140PSI)
- Work light (LED lamp)
- Splash guard with side coolant tank
- Tool/Work box
- Hyd. Hollow chuck
- Leveling blocks
- Chuck clamp foot switch
- Chuck clamp confirmation
- Manual/Part list
- Door interlock
- Tailstock in-out foot switch

Optional Accessories

- Chip conveyor
- Dual pressure chucking
- Auto door
- Oil skimmer
- Part catcher [NL2500(M) only]
- Coolant gun
- Tool presetter

NL 4000 | 5000 18", 21" Chuck / A2-11, A2-15 spindle nose



NL 4000

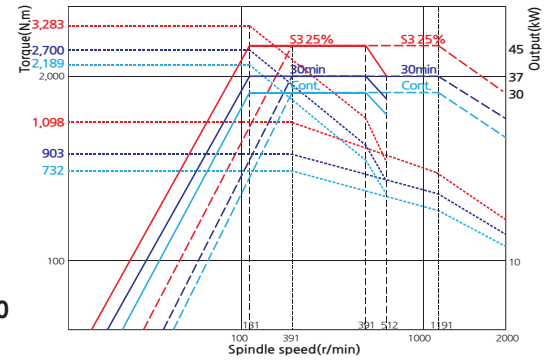

NL 5000

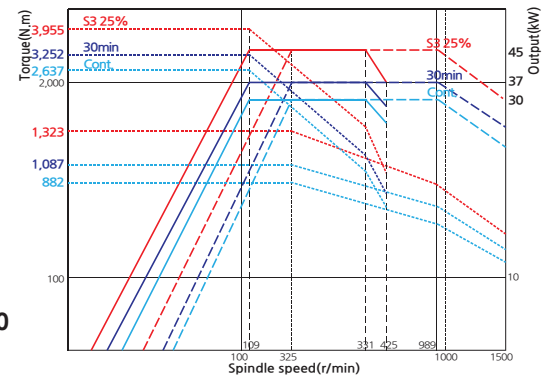

Turret Head Interference Unit: mm(inch)

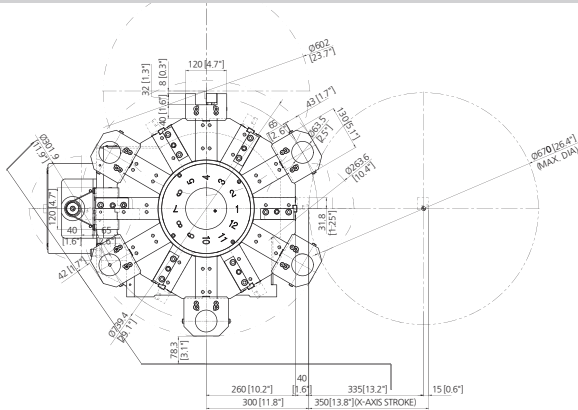

NL 5000

Work Range Unit: mm(inch)

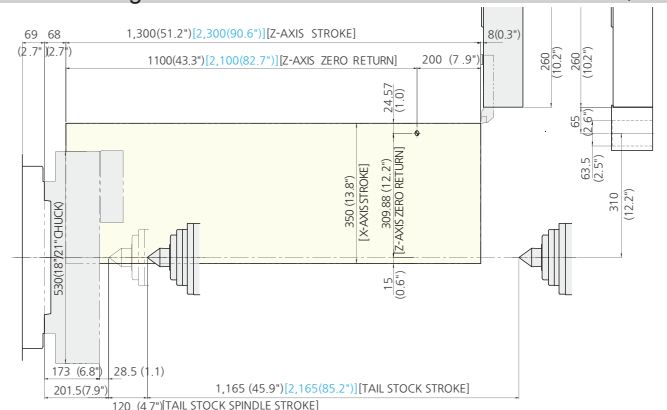

NL 5000/1200 [NL 5000/2200]

Machine Dimensions Unit: mm(inch)

NL 4000/1200 | NL 5000/1200 [NL 5000/2200]

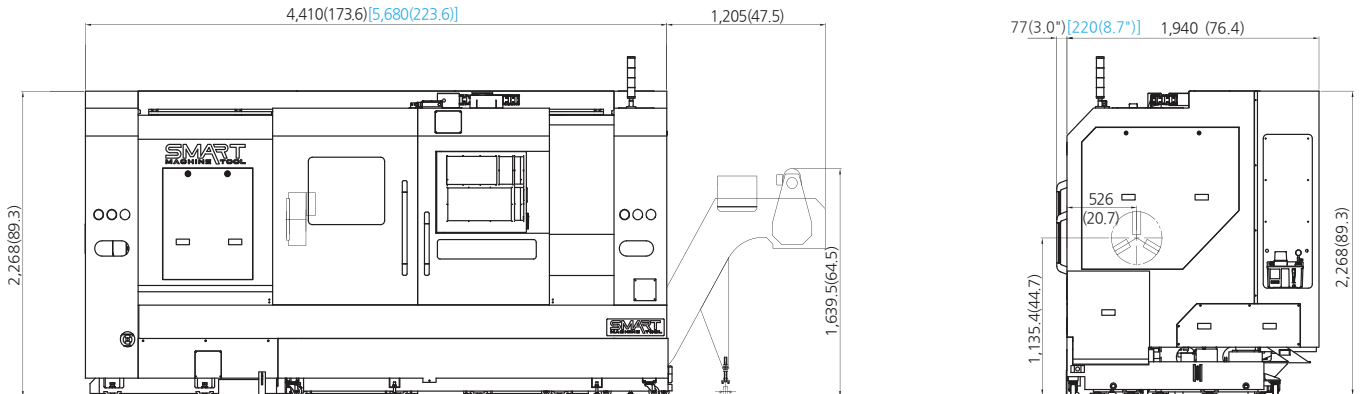

Machine Specifications

DESCRIPTION			NL 4000/1200	NL 4000M/1200	NL 5000/1200 [NL 5000/2200]	NL 5000M/1200 [NL 5000M/2200]
CAPACITY	Swing over the bed	mm(inch)	790(31.1)		900(35.43)	
	Swing over the cross slide	mm(inch)	610(24.02)		690(27.17)	
	Max. machining diameter	mm(inch)	648(25.51)	638(25.11)	670(26.38)	650(25.59)
	Max. machining length	mm(inch)	1,213(47.76)	1,145(45.08)	1,155(45.47) [2,155(84.84)]	1,119(44.06) [2,119(83.43)]
	Chuck size	Inch	18		21	
	Bar working dia.	mm(inch)	116.5 (4.59)		165.5 (6.52)	
SPINDLE	Spindle speed	rpm	2,000		1,500	
	Spindle motor (Cont./Max.)	kW(Hp)	30/45(40/60)			
	Spindle nose	ASA	A2-11		A2-15	
	Spindle torque (Max.)	N.m(ft.lbs)	3,283(2,421)		3,955(2,917)	
	Spindle through hole dia.	mm(inch)	132(5.2)		181(7.125)	
TRAVEL	Rapid traverse (X/Z)	m/min(ipm)	16/20(630/787)			
	X-axis travel	mm(inch)	340(13.39)		350(13.78)	
	Z-axis travel	mm(inch)	1,300(51.18)		1,300(51.18) [2,300(90.55)]	
	Feed motor (X/Z)	kW(hp)	4/7(5.4/9.4)		7/6(9.4/8)	
TURRET	Number of tool stations	st.	12			
	OD tool size	mm(inch)	□32(1.25)			
	Max. boring bar size	mm(inch)	Ø60(2.5)			
	Indexing time	sec	0.25/step			
	Milling tool holder type	-	-	BMT75	-	BMT75
	Max. rotary tool spindle speed	rpm	-	4,000	-	4,000
	Rotary tool motor power	kW(hp)	-	7.5/11/15 (10/14.8/20.1)	-	7.5/11/15 (10/14.8/20.1)
TAILSTOCK	Tailstock travel	mm(inch)	1,165(45.87)		1,165(45.87) [2,165(85.24)]	
	Quill diameter	mm(inch)	140(5.51)			
	Quill travel	mm(inch)	120(4.72)			
	Taper of tailstock spindle	-	MT#5 (Built-in)			
BED TYPE		-	45° Slant			
ELECTRIC POWER SUPPLY		kVA	55			
REQUIRED FLOOR SPACE		mm(inch)	4,450x2,017(175.2x79.4)		4,450x2,017(175.2x79.4) [5,720x2,205(225.2x86.8)]	
MACHINE WEIGHT		kg(lbs)	10,700(23,589)	1,0800(23,810)	10,800(23,810) [13,700(30,203)]	10,900(24,030) [13,800(30,424)]
CONTROLLER		-	Fanuc 0i-TF			

- Figures in inches are converted from metric measurements.
- Design and specifications are subject to change without notice.

Standard Accessories

- Coolant unit 10bar (140PSI)
- Work light (LED lamp)
- Splash guard with side coolant tank
- Tool/Work box
- Hyd. Hollow chuck
- Leveling blocks
- Chuck clamp foot switch
- Chuck clamp confirmation
- Manual/Part list
- Door interlock
- Tailstock in-out foot switch

Optional Accessories

- Chip conveyor
- Dual pressure chucking
- Auto door
- Coolant gun
- Tool presetter
- Oil skimmer
- Steady rest prep

Machine Specifications

DESCRIPTION			NL 6000/750	NL 6000M/750	NL 6000/1500	NL 6000M/1500
CAPACITY	Swing over the bed	mm(inch)	1,030(40.55)			
	Swing over the cross slide	mm(inch)	850(33.46)			
	Max. machining diameter	mm(inch)	960(37.80)	900(35.43)	960(37.80)	900(35.43)
	Max. machining length	mm(inch)	750(29.53)	700(27.56)	1,550(61.02)	1,500(59.06)
	Chuck size	Inch	24			
	Bar working dia.	mm(inch)	165.5(6.52)			
SPINDLE	Spindle speed	rpm	1,200			
	Spindle motor (Cont./Max.)	kW(Hp)	37/55(50/73)			
	Spindle nose	ASA	A1-15			
	Spindle torque (Max.)	N.m(ff.lbs)	5,143(3,793.3)			
	Spindle through hole dia.	mm(inch)	181(7.125)			
TRAVEL	Rapid traverse (X/Z)	m/min(ipm)	16/20(630/787)			
	Travel (X/Z)	mm(inch)	475/800 (18.7/31.5)		475/1,600(18.7/63)	
	Feed motor (X/Z)	kW(hp)	7/6(9.4/8)			
TURRET	Number of tool stations	st.	12			
	OD tool size	mm(inch)	□32(□1.25)			
	Max. boring bar size	mm(inch)	Ø80(3)			
	Indexing time	sec	0.25/Step	0.35/Step	0.25/Step	0.35/Step
	Milling tool holder type	-	-	BMT85	-	BMT85
	Max. rotary tool spindle speed	rpm	-	3,000	-	3,000
	Rotary tool motor power	kW(hp)	-	7.5/11/15 (10/14.8/20.1)	-	7.5/11/15 (10/14.8/20.1)
TAILSTOCK	Tailstock travel	mm(inch)	[Option]		1,450(57.09)	
	Quill diameter	mm(inch)	[Option]		180(7.09)	
	Quill travel	mm(inch)	[Option]		150(5.91)	
	Taper of tailstock spindle	-	[Option]		MT#6 (Built-in)	
BED TYPE		-	45° Slant			
ELECTRIC POWER SUPPLY		kVA	65			
REQUIRED FLOOR SPACE		mm(inch)	4,390x2,379(172.8x93.7)		5,191x2,379(204.4x93.7)	
MACHINE WEIGHT		kg(lbs)	11,500(25,353)	12,000(26,455)	15,300(33,371)	15,800(34,833)
CONTROLLER		-	Fanuc 0i-TF			

- Figures in inches are converted from metric measurements.
- Design and specifications are subject to change without notice.

[] : Option

Standard Accessories

- Coolant unit 10bar (140PSI)
- Work light (LED lamp)
- Splash guard with side coolant tank
- Tool/Work box
- Hyd. Hollow chuck
- Leveling blocks
- Chuck clamp foot switch
- Chuck clamp confirmation
- Manual/Part list
- Door interlock
- Tailstock in-out foot switch

Optional Accessories

- Chip conveyor
- Dual pressure chucking
- Auto door
- Coolant gun
- Tool presetter
- Oil skimmer
- Steady rest prep

Machine Specifications

DESCRIPTION			NL 6000/2200	NL 6000M/2200	NL 6000/3200	NL 6000M/3200
CAPACITY	Swing over the bed	mm(inch)	1,030(40.55)			
	Swing over the cross slide	mm(inch)	850(33.46)			
	Max. machining diameter	mm(inch)	960(37.80)	900(35.43)	960(37.80)	900(35.43)
	Max. machining length	mm(inch)	2,250(88.58)	2,200(86.61)	3,250(127.95)	3,200(125.98)
	Chuck size	Inch	24			
	Bar working dia.	mm(inch)	165.5(6.52)			
SPINDLE	Spindle speed	rpm	1,200			
	Spindle motor (Cont./Max.)	kW(Hp)	37/55(50/73)			
	Spindle nose	ASA	A1-15			
	Spindle torque (Max.)	N.m(ff.lbs)	5,143(3,793.3)			
	Spindle through hole dia.	mm(inch)	181(7.125)			
TRAVEL	Rapid traverse (X/Z)	m/min(ipm)	16/16(630/630)		16/10(630/394)	
	Travel (X/Z)	mm(inch)	475/2,300 (18.7/90.55)		475/3,300(18.7/129.92)	
	Feed motor (X/Z)	kW(hp)	7/6(9.4/8)			
TURRET	Number of tool stations	st.	12			
	OD tool size	mm(inch)	□32(□1.25)			
	Max. boring bar size	mm(inch)	Ø80(3)			
	Indexing time	sec	0.25/Step	0.35/Step	0.25/Step	0.35/Step
	Milling tool holder type	-	-	BMT85	-	BMT85
	Max. rotary tool spindle speed	rpm	-	3,000	-	3,000
	Rotary tool motor power	kW(hp)	-	7.5/11/15 (10/14.8/20.1)	-	7.5/11/15 (10/14.8/20.1)
TAILSTOCK	Tailstock travel	mm(inch)	2,150(86.65)		3,150(124.02)	
	Quill diameter	mm(inch)	180(7.09)			
	Quill travel	mm(inch)	150(5.91)			
	Taper of tailstock spindle	-	MT#6 (Built-in)			
BED TYPE	-	45° Slant				
ELECTRIC POWER SUPPLY	kVA	65				
REQUIRED FLOOR SPACE	mm(inch)	6,004x2,389(236.4x94.1)			7,100x2,469(279.5x97.2)	
MACHINE WEIGHT	kg(lbs)	17,300(38,140)	17,800(39,242)	19,800(43,652)	20,300(44,754)	
CONTROLLER	-	Fanuc 0i-TF				

- Figures in inches are converted from metric measurements.
- Design and specifications are subject to change without notice.

Standard Accessories

- Coolant unit [10bar (140PSI)]
- Work light (LED lamp)
- Splash guard with side coolant tank
- Tool/Work box
- Hyd. Hollow chuck
- Leveling blocks
- Chuck clamp foot switch
- Chuck clamp confirmation
- Manual/Part list
- Door interlock
- Tailstock in-out foot switch

Optional Accessories

- Chip conveyor
- Dual pressure chucking
- Auto door
- Coolant gun
- Tool presetter
- Oil skimmer
- Steady rest prep

Machine Specifications

DESCRIPTION		NL 6000C/1500	NL 6000C/2200	NL 6000C/3200	
CAPACITY	Swing over the bed	mm(inch)	1,030(40.55)		
	Swing over the cross slide	mm(inch)	850(33.46)		
	Max. machining diameter	mm(inch)	960(37.80)	960(37.80)	960(37.80)
	Max. machining length	mm(inch)	1,550(61.02)	2,250(88.58)	3,250(127.95)
	Chuck size	Inch	[user scope]		
	Bar working dia.	mm(inch)	[-]		
SPINDLE	Spindle speed	rpm	1,000		
	Spindle motor (Cont./Max.)	kW(Hp)	37/55(50/73)		
	Spindle nose	ASA	A1-20		
	Spindle torque (Max.)	N.m(ft.lbs)	5,143(3,793.3)		
	Spindle through hole dia.	mm(inch)	275(10.83)		
TRAVEL	Rapid traverse (X/Z)	m/min(ipm)	16/20(630/787)	16/16(630/630)	16/10(630/394)
	Travel (X/Z)	mm(inch)	475/1,600(18.7/63)	475/2,300(18.7/90.55)	475/3,300(18.7/129.92)
	Feed motor (X/Z)	kW(hp)	7/6(9.4/8)		
TURRET	Number of tool stations	st.	12		
	OD tool size	mm(inch)	□32(□1.25)		
	Max. boring bar size	mm(inch)	Ø80(3)		
	Indexing time	sec	0.25/Step		
	Milling tool holder type	-	-		
	Max. rotary tool spindle speed	rpm	-		
	Rotary tool motor power	kW(hp)	-		
TAILSTOCK	Tailstock travel	mm(inch)	1,450(57.09)	2,150(84.65)	3,150(124.02)
	Quill diameter	mm(inch)	180(7.09)		
	Quill travel	mm(inch)	150(5.91)		
	Taper of tailstock spindle	-	MT#6 (Built-in)		
BED TYPE	-	45° Slant			
ELECTRIC POWER SUPPLY	kVA	65			
REQUIRED FLOOR SPACE	mm(inch)	5,191x2,379(204.4x93.7)	6,004x2,389(236.4x94.1)	7,100x2,469(279.5x97.2)	
MACHINE WEIGHT	kg(lbs)	15,300(33,371)	17,300(38,140)	19,800(43,652)	
CONTROLLER	-	Fanuc Oi-TF			

- Figures in inches are converted from metric measurements.
- Design and specifications are subject to change without notice.

[] : Option

Standard Accessories

- Coolant unit 10bar (140PSI)
- Work light (LED lamp)
- Splash guard with side coolant tank
- Tool/Work box
- Leveling blocks
- Manual/Part list
- Door interlock
- Tailstock in-out foot switch

Optional Accessories

- Chip conveyor
- Dual pressure chucking
- Auto door
- Coolant gun
- Tool presetter
- Oil skimmer
- Steady rest prep

6, 8, 10, 15, 18, 21 Inch Chuck Y-Axis Turning Centers

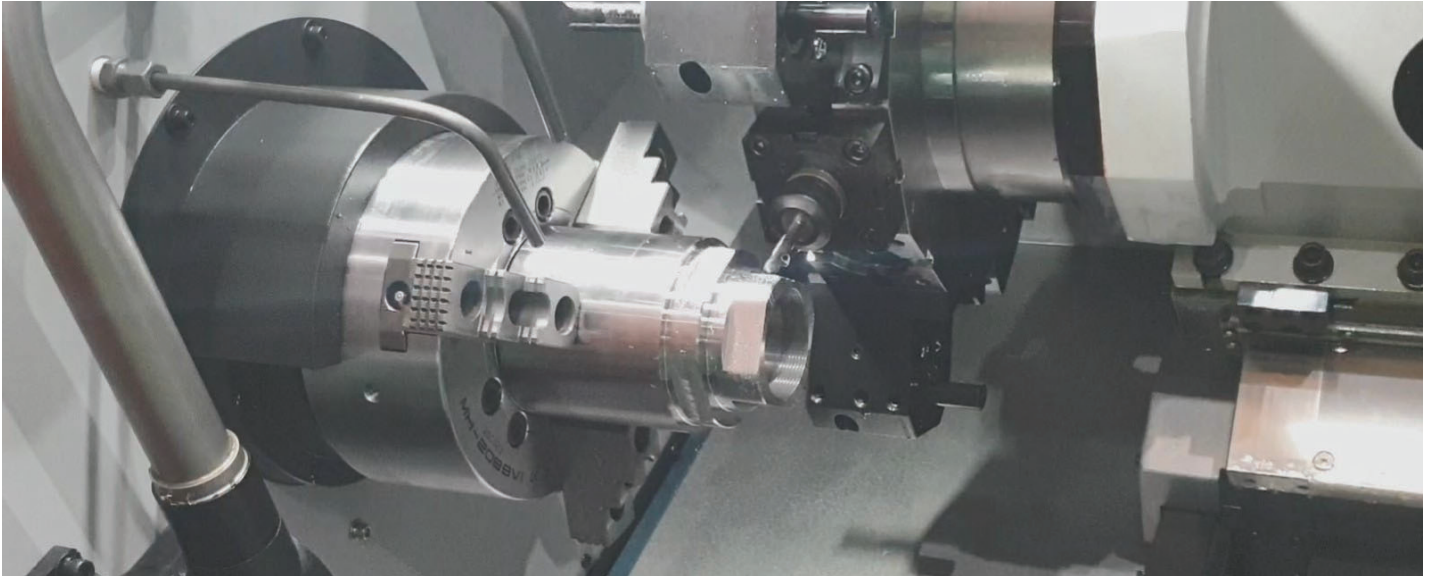

12-Station (24 Position) BMT Turret

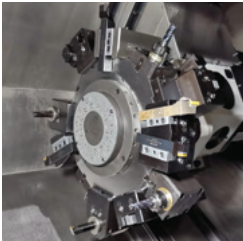

BMT turret is equipped with 2 separated motors for indexing and milling, ensuring high machining performance, reliability and reducing processing time of workpiece.

Sub Spindle (SY Models)

Equipped with built-in motor and oil cooling unit as standard to minimize thermal displacement and ensure maximum machining accuracy even during a long period of machining.

Servo Tailstock (Y Models)

Servo tailstock is available as standard feature for Y models, offers better machining efficiency and reduce set-up time.

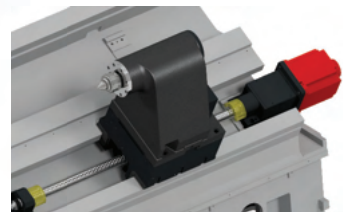

Main Spindle

Spindle cartridge is designed to be exposed to air in all directions dissipating heat generated by axis movements, maintaining minimal thermal expansion.

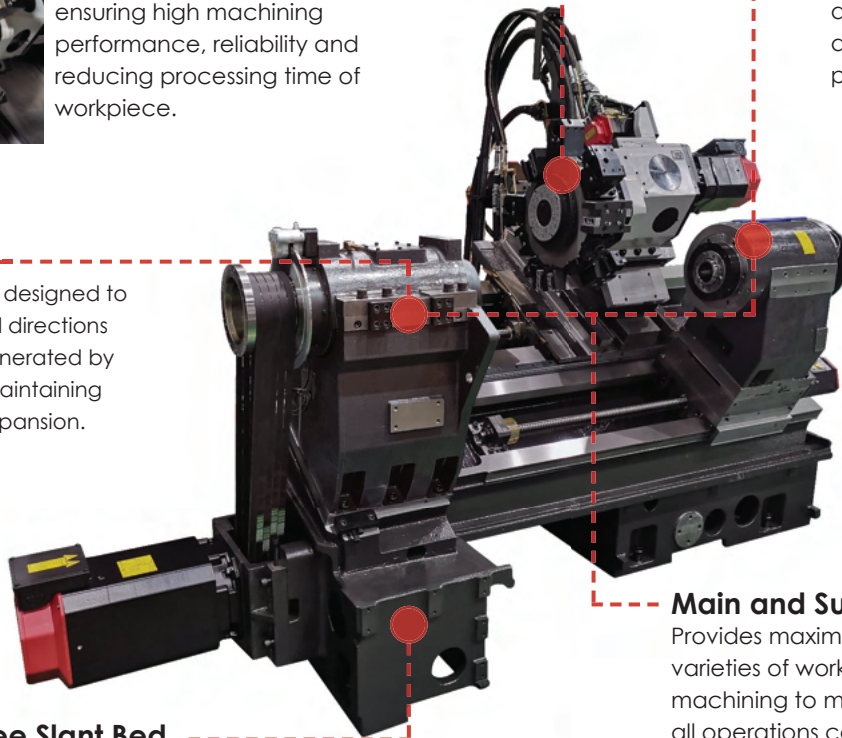

Main and Sub Spindle Synchronization

Provides maximum machining flexibility for varieties of workpiece configuration. From simple machining to multi-axis simultaneous machining, all operations can be completed in one set-up.

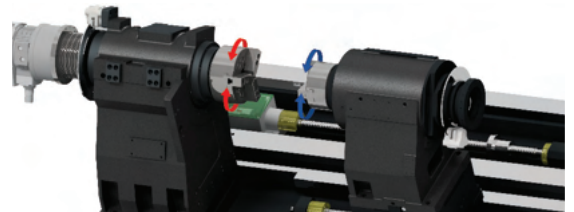

Rigid 30 Degree Slant Bed

One-piece casting 30 degree slant torque tube design bed which provides maximum vibration dampening and improve machining stability during heavy duty cutting.

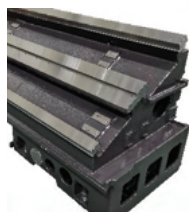

Y-Axis Machining Capability

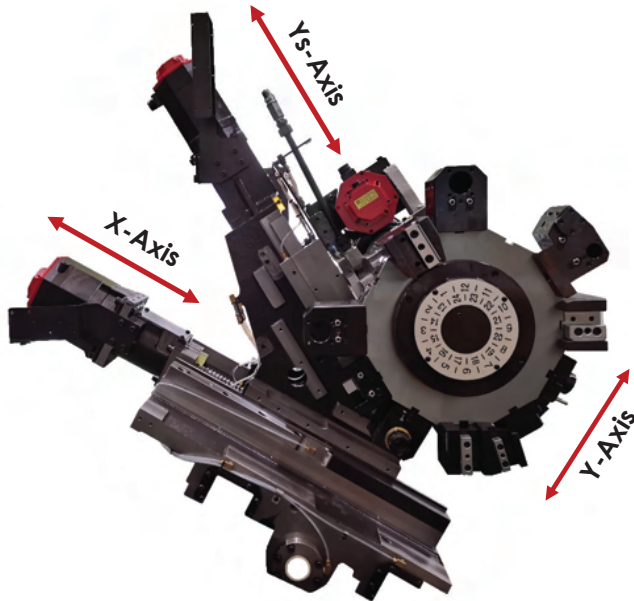

Y-axis allows side milling, off-center drilling and grooving. This result in better machining accuracy and also enable more complex shape machining capability compared to conventional 2 and 3 axis turning center.

The simultaneous operation of the X-axis and the Ys-axis creates the Y-axis movement.

Y-Axis Travel

110 (± 55) mm [4.33 (± 2.17) inch]

Y-Axis Rapid Traverse

10 m/min [394 ipm]

■ Side milling

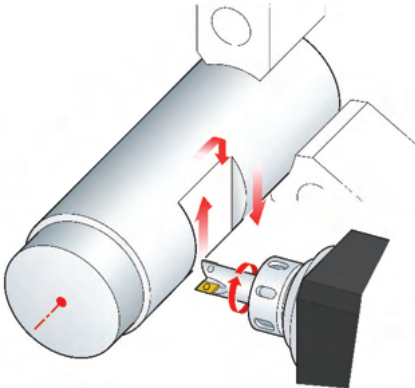

■ Off-center grooving

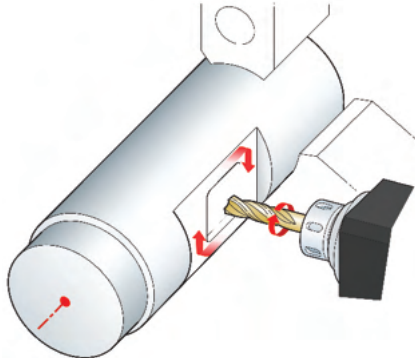

■ Off-center drilling

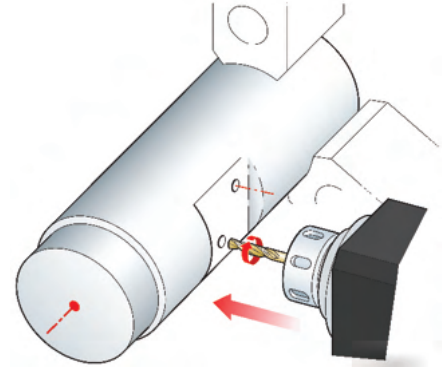

Y-axis control compared to Polar coordinate interpolation

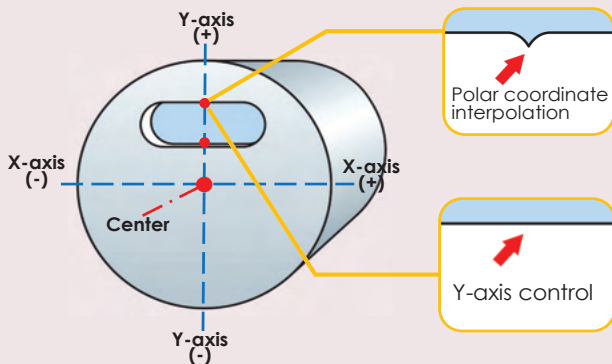

Polar coordinate interpolation control during grooving and contouring, the X-axis reverses at cross point between the center line and the profile to be machined which cause change in cutting condition and affect profile accuracy. Machining with Y-axis control can avoid such issue and also provide better profile accuracy.

Milling without Y-axis control

Width of outer and inner grooves are not perfectly parallel.

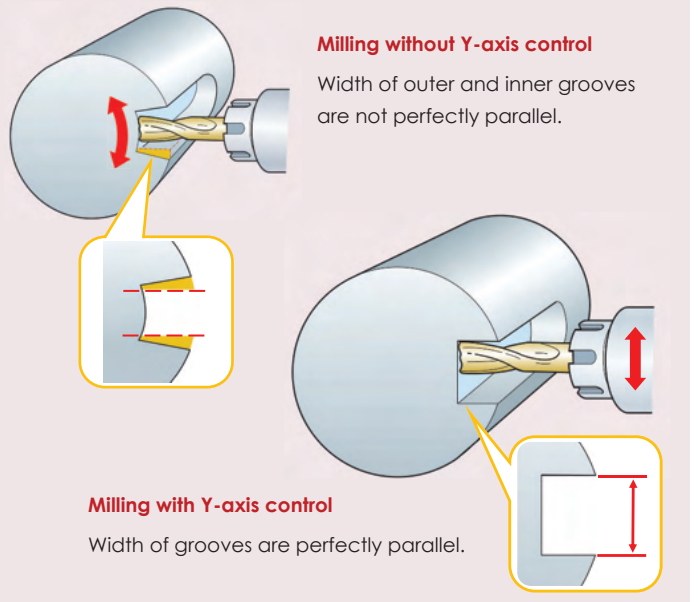

Milling with Y-axis control

Width of grooves are perfectly parallel.

NL 2000SY-Y | NL 2500SY-Y 6" - 10" Chuck / A2-5, A2-6, A2-8 spindle nose



NL 2000ASY | AY

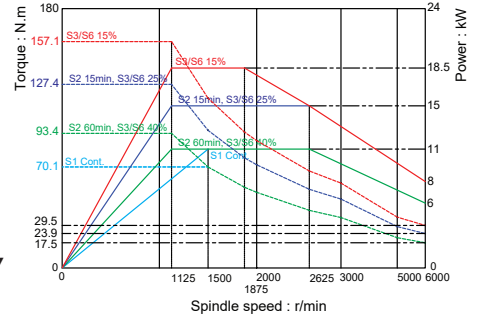

NL 2500SY | Y

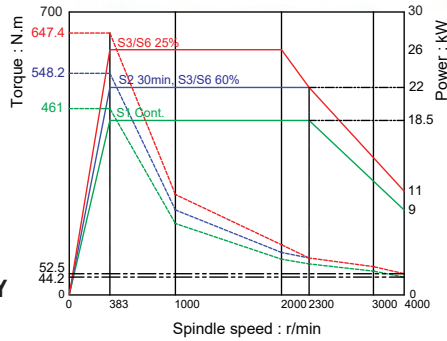

NL 2000BSY | BY

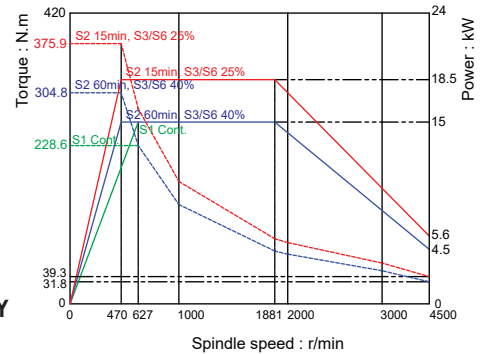

Turret Head Interference Unit: mm(inch)

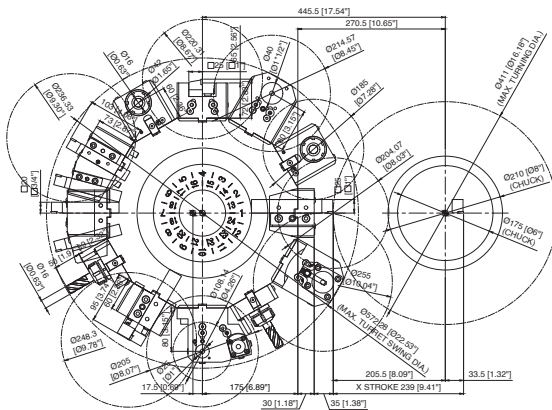

NL 2000ASY/BSY

Work Range Unit: mm(inch)

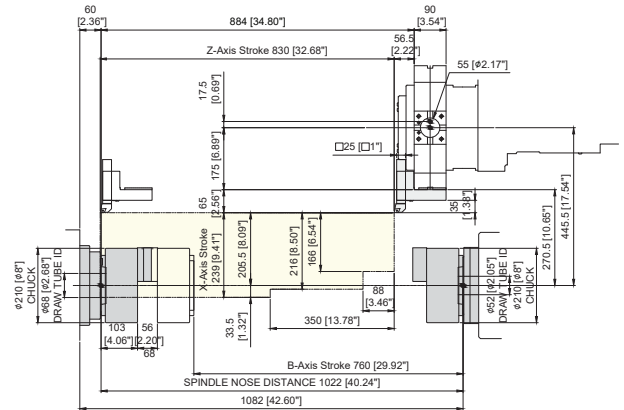

NL 2000BSY

Machine Dimensions Unit: mm(inch)

[48(1.89")][163(6.52")]

NL 2000ASY [NL 2000BSY] [NL 2500SY]

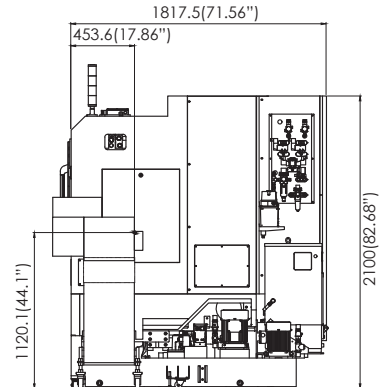
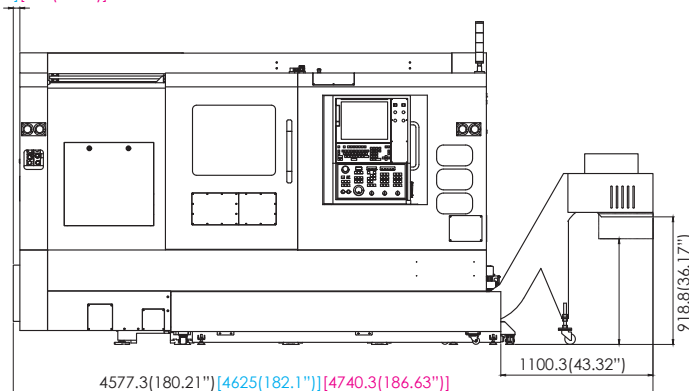

Machine Specifications

DESCRIPTION		NL 2000ASY [NL 2000BSY]	NL 2000AY [NL 2000BY]	NL 2500SY	NL 2500Y		
CAPACITY	Swing over the bed	mm(inch)	810(31.89)				
	Swing over the cross slide	mm(inch)	720(28.35)				
	Max. machining diameter	mm(inch)	411(16.18)		394(15.51)		
	Max. machining length	mm(inch)	750(29.53) [735(28.94)]	726.5(28.6) [711.5(28.01)]	713(28.07)	690(27.17)	
MAIN SPINDLE	Chuck size	inch	6 [8]		10		
	Bar working dia.	mm(inch)	51(2) [65(2.56)]		81(3.19)		
	Spindle speed	rpm	6,000 [4,500]		4,000		
	Spindle motor (Cont./Max.)	kW(Hp)	11/18.5(15/25) [15/18.5(20/25)]		18.5/26(25/35)		
	Spindle nose	ASA	A2-5 [A2-6]		A2-8		
	Spindle torque (Max.)	N.m(ft.lbs)	157(115.8) [376(277.3)]		647.4(477.5)		
	Spindle through hole dia.	mm(inch)	61(2.4) [76(2.99)]		91(3.58)		
SUB SPINDLE	Chuck size	inch	6 [8]	-	8	-	
	Bar working dia.	mm(inch)	51(2)	-	51(2)	-	
	Spindle speed	rpm	6,000 [5,000]	-	5,000	-	
	Spindle motor (Cont./Max.)	kW(Hp)	11/15(15/20)	-	11/15(15/20)	-	
	Spindle nose	ASA	A2-5 [A2-6]	-	A2-6	-	
	Spindle torque (Max.)	N.m(ft.lbs)	135(99.6)	-	135(99.6)	-	
	Spindle through hole dia.	mm(inch)	62(2.44)	-	62(2.44)	-	
TRAVEL	Rapid traverse (X/Z/Y/B)	m/min(ipm)	30/30/10/30(1,181/1,181/394/1,181)				
	Travel	X/Z	mm(inch)	239/830(9.41/32.68)	239/830(9.41/32.68)	248.5/830(9.78/32.68)	248.5/830(9.78/32.68)
		Y/B	mm(inch)	110/790(4.33/31.1) [110/760(4.33/29.92)]	110/830(4.33/32.68)	110/760(4.33/29.92)	110/830(4.33/32.68)
	Feed motor (X/Z/Y/B)	kW(hp)	3/3/1.8/3(4/4/2.4/4)				
TURRET	Number of tool stations	st.	12(24)				
	OD tool size	mm(inch)	□25(□1)				
	Max. boring bar size	mm(inch)	Ø40(1.5)		Ø50(2)		
	Indexing time	sec	0.15/Step				
	Milling tool holder type	-	BMT55		BMT65		
	Max. rotary tool spindle speed	rpm	5,000				
	Rotary tool motor power	kW(hp)	3.7/5.5(5/7.4)		3.7/5.5/7.5(5/7.4/10)		
TAILSTOCK	Tailstock travel	mm(inch)	-	830(32.68)	-	830(32.68)	
	Taper of tailstock spindle	-	-	MT#5 live center	-	MT#5 live center	
BED TYPE	-	30° Slant					
ELECTRIC POWER SUPPLY	kVA	40		45			
REQUIRED FLOOR SPACE	mm(inch)	3,570x1,818(140.55x71.57)		3,700x1,818(145.67x71.57)			
MACHINE WEIGHT	kg(lbs)	5,700(12,566) [5,800(12,787)]	5,600(12,345) [5,700(12,566)]	6,100(13,448)	6,000(13,228)		
CONTROLLER	-	Fanuc 0i-TF					

- Figures in inches are converted from metric measurements.
- Design and specifications are subject to change without notice.

Standard Accessories

- Coolant unit 20bar (290PSI)
- Work light (LED lamp)
- Splash guard with side coolant tank
- Tool/Work box
- Hyd. Hollow chuck
- Leveling blocks
- Chuck clamp foot switch
- Chuck clamp confirmation
- Manual/Part list
- Door interlock

Optional Accessories

- Chip conveyor
- Dual pressure chucking
- Auto door
- Oil skimmer
- Main part catcher
- Sub part catcher with internal part conveyor (Only SY model)
- Work ejector (Only SY model)
- Air blower
- Coolant gun
- Tool presetter

NL 3500Y | 4000Y | 5000Y 15", 18", 21" Chuck / A2-11, A2-15 spindle nose, With Y-Axis

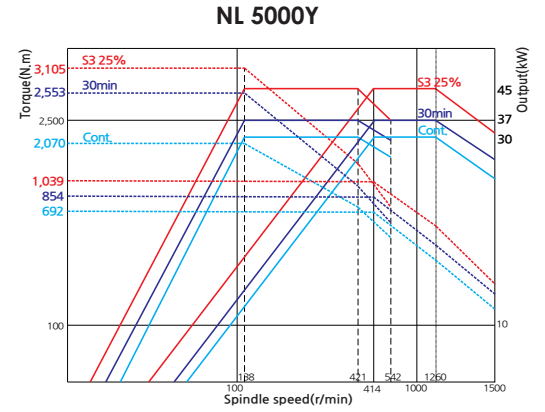

Turret Head Interference Unit: mm(inch)

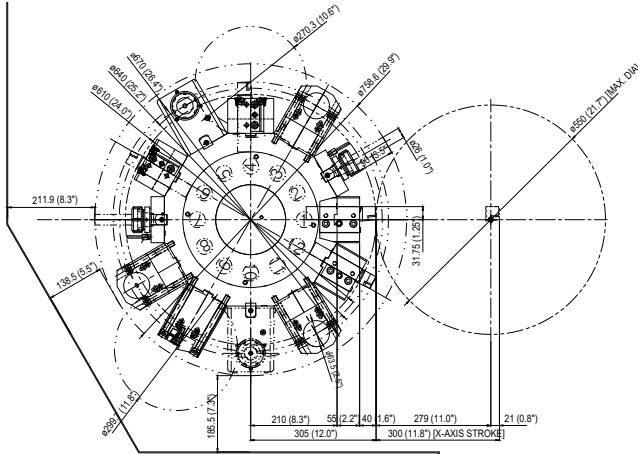

Work Range Unit: mm(inch)

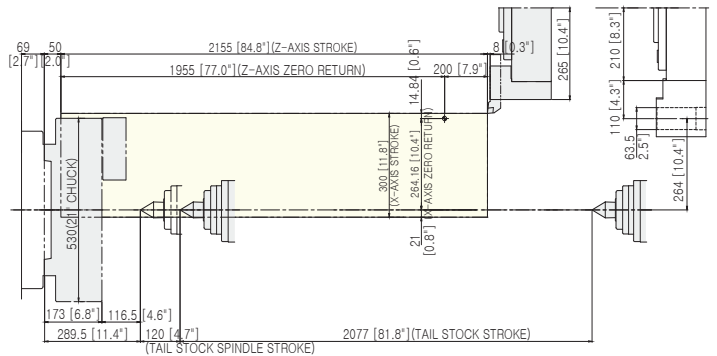

Machine Dimensions Unit: mm(inch)

NL 4000LY | NL5000LY

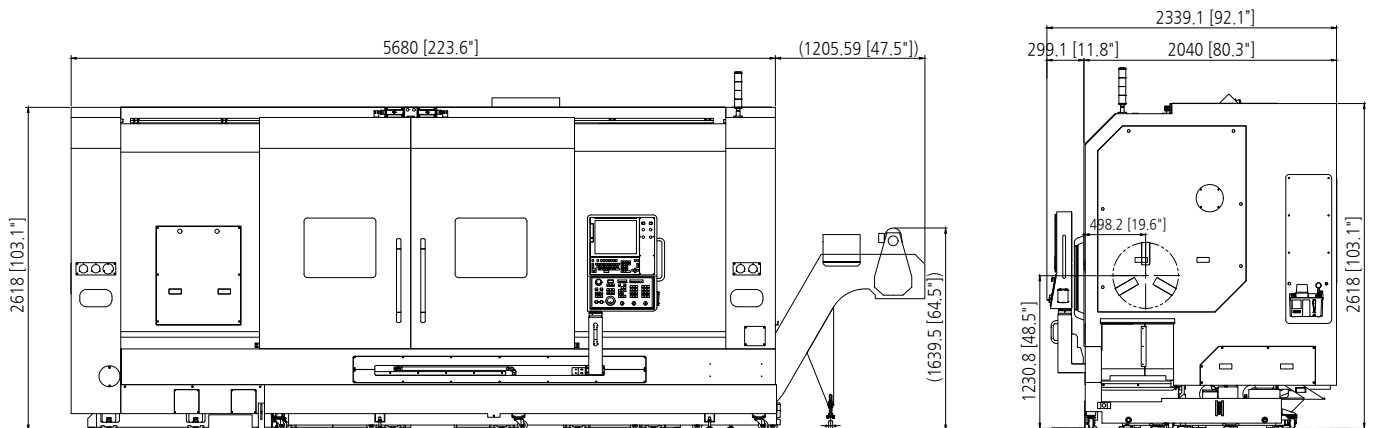

Machine Specifications						
DESCRIPTION			NL 3500BY	NL 3500BXY	NL 4000LY	NL 5000LY
CAPACITY	Swing over the bed	mm(inch)	850(33.5)		900(35.43)	
	Swing over the cross slide	mm(inch)	670(26.4)		850(33.46)	
	Max. machining diameter	mm(inch)	430(16.9)		550(21.65)	
	Max. machining length	mm(inch)	1,470(57.9)	2,970(116.9)	2,017(79.41)	1,992(78.43)
	Chuck size	Inch	15(12 opt.)		18	21
	Bar working dia.	mm(inch)	116.5(4.59)		116.5(4.59)	165.5(6.52)
SPINDLE	Spindle speed	rpm	2,000		2,000	1,500
	Spindle motor (Cont./Max.)	kW(Hp)	22/30(30/40)		30/45(40/60)	
	Spindle nose	ASA	A2-11		A2-11	A2-15
	Spindle torque (Max.)	N.m(ft.lbs)	1,611(1,188.9)		2,687(1,981)	3,105(2,289)
	Spindle through hole dia.	mm(inch)	132(5.2)		132(5.2)	181(7.13)
TRAVEL	Rapid traverse (X/Z/Y)	m/min(ipm)	30/30/10 (1,181/1,181,394)		16/20/10(630/787/394)	
	Travel (X/Z/Y)	mm(inch)	295/1,570/130 (11.6/61.6/5.12)	295/3,065/130 (11.6/120.7/5.12)	300/2,155/150(11.81/84.84/5.91)	
	Feed motor (X/Z/Y)	kW(hp)	4/7/4(5.4/9.4/5.4)		7/6/7(9.4/8/9.4)	
TURRET	Number of tool stations	st.	12		12	
	OD tool size	mm(inch)	□25(1)		□32(1.25)	
	Max. boring bar size	mm(inch)	Ø50(2)		Ø60(2.5)	
	Indexing time	sec	0.25/step		0.25/step	
	Milling tool holder type	-	BMT65		BMT75	
	Max. rotary tool spindle speed	rpm	5,000		4,000	
	Rotary tool motor power	kW(hp)	7.5/11(10/14.8)		7.5/11/15 (10/14.8/20.1)	
TAILSTOCK	Tailstock travel	mm(inch)	1,500(59.06)	3,000(118.11)	2,077(81.77)	
	Quill diameter	mm(inch)	140(5.51)		140(5.51)	
	Quill travel	mm(inch)	120(4.72)		120(4.72)	
	Taper of tailstock spindle	-	MT#5 (Built-in)		MT#5 (Built-in)	
BED TYPE		-	30° Slant		45° Slant	
ELECTRIC POWER SUPPLY		kVA	56		60	
REQUIRED FLOOR SPACE		mm(inch)	4,700x2,105 (185.0x82.9)	6,722x2,280 (264.6x89.8)	5,720x2,340(225.2x92.1)	
MACHINE WEIGHT		kg(lbs)	8,200(18,078)	11,000(24,251)	14,800(32,628)	15,000(33,069)
CONTROLLER		-	Fanuc 0i-TF			

- Figures in inches are converted from metric measurements.
- Design and specifications are subject to change without notice.

Standard Accessories

- Coolant unit 10bar (140PSI)
- Work light (LED lamp)
- Splash guard with side coolant tank
- Tool/Work box
- Hyd. Hollow chuck
- Leveling blocks
- Chuck clamp foot switch
- Chuck clamp confirmation
- Manual/Part list
- Door interlock
- Tailstock in-out foot switch

Optional Accessories

- Chip conveyor
- Dual pressure chucking
- Auto door
- Coolant gun
- Tool presetter
- Oil skimmer
- Steady rest prep

Turning Performance

Heavy-duty cutting <O.D.>

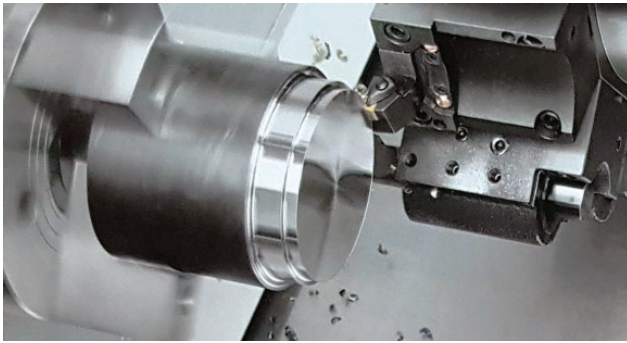

Machine type	NL 2500
Material <JIS>	S45C
Spindle speed	367 min ⁻¹
Depth of cut	8 mm (0.312 inch)
Cutting speed	152 m/min (500 fpm)
Feedrate	0.5 mm/rev (0.020 ipr)

Insert Drill

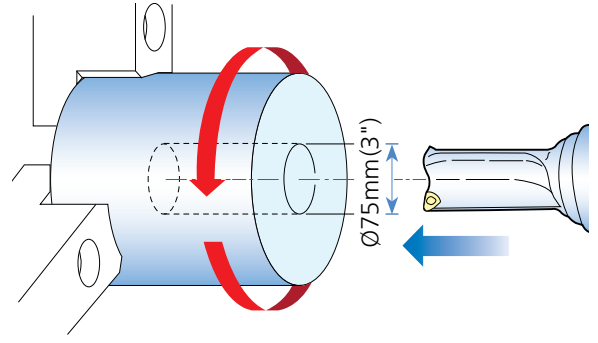

Machine type	NL 2500
Material <JIS>	S45C
Spindle speed	417 min ⁻¹
Drill diameter	75 mm (3 inch)
Feedrate	0.15 mm/rev (0.006 ipr)

Milling Capacity (material <JIS>:S45C)

End mill <Ø20mm(0.8") High-speed steel>

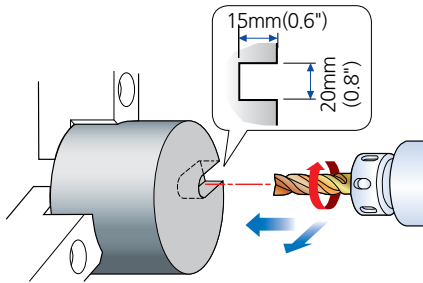

Drill <Ø20mm(0.8") High-speed steel>

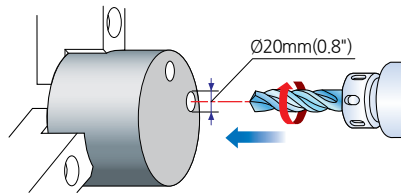

Tap <N18xP2.5>

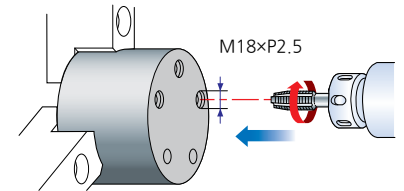

Machine type	NL 2500
Material <JIS>	S45C
Rotary tool spindle speed	320 min ⁻¹
Depth of cut	15 mm (0.6 inch)
Cutting speed	20 m/min (65.6 fpm)
Feedrate	65 mm/min (2.5 ipm)

Machine type	NL 2500
Material <JIS>	S45C
Rotary tool spindle speed	391 min ⁻¹
Cutting speed	25 m/min (82.0 fpm)
Feedrate	105 mm/min (4.1 ipm)

Machine type	NL 2500
Material <JIS>	S45C
Rotary tool spindle speed	160 min ⁻¹
Cutting speed	10 m/min (32.8 fpm)
Feedrate	400 mm/min (15.7 ipm)

Rotary Tool Spindle Output Diagram

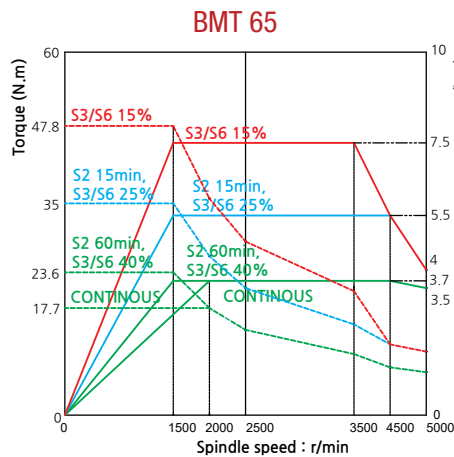

NL 2500 | NL 3000

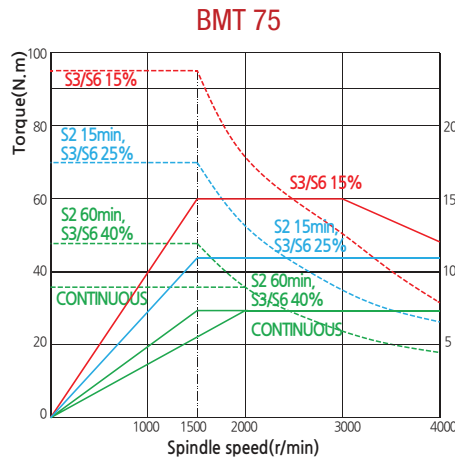

NL 4000 | NL 5000

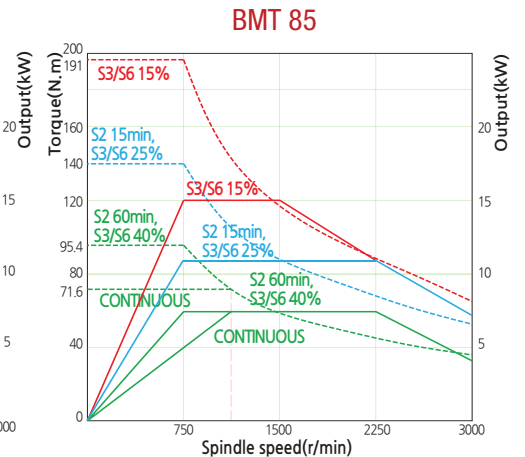

NL 6000

Tooling System

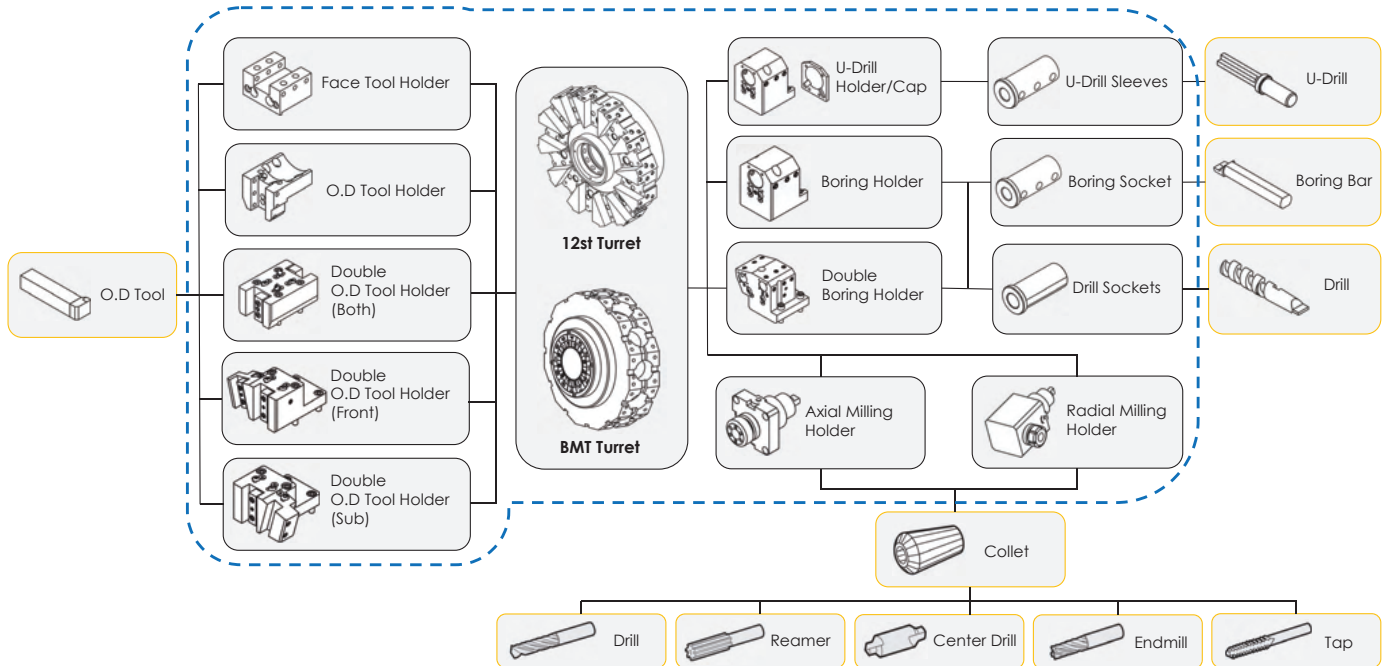

Standard Tooling Packages

Unit: mm(inch)

ITEM		NL1500 NL2000	NL1500M NL2000M	NL2500 NL3000	NL2500M NL3000M	NL4000 NL5000	NL4000M/Y NL5000M/Y	NL6000	NL6000M	NL 2000SY	NL 2500SY	NL2000Y	NL2500Y	
Turning Holder	O.D Holder	Single	-	3	-	3	1	4	1	4	1	1	2	3
		Double(Both)	-	-	-	-	-	-	-	-	1	3	-	-
		Double(Front)	-	-	-	-	-	-	-	-	1	1	1	1
		Double(Sub)	-	-	-	-	-	-	-	-	1	-	-	-
Facing Holder	-	2	1	2	1	1	1	1	1	1	-	1	1	
	U-Drill holder	6	4	6	4	1	1	2	1	2	2	3	2	
Boring Holder	Double	-	-	-	-	-	-	-	-	1	1	1	1	
	Boring holder	-	-	-	-	4	2	3	2	2	2	-	-	
Driven Holder	Axial Milling Holder	Standard	-	1	-	1	-	1	-	1	1	1	1	
	Radial Milling Holder	Standard	-	1	-	1	-	1	-	1	1	1	1	
Sleeve	Boring	Ø10(3/8")	1	1	1	1	-	-	-	1	1	1	1	
		Ø12(1/2")	1	1	1	1	1	1	-	-	1	1	1	
		Ø16(5/8")	1	1	1	1	1	1	1	1	1	1	1	
		Ø20(3/4")	2	2	2	2	1	1	1	1	1	1	1	
		Ø25(1")	2	2	2	2	1	1	1	1	1	1	1	
		Ø32(1 1/4")	2	2	2	2	1	1	1	1	1	1	1	
		Ø40(1 1/2")	-	-	2	2	1	1	1	1	-	1	-	1
		Ø50(2")	-	-	-	-	1	1	1	1	-	-	-	-
	Ø60(2 1/2")	-	-	-	-	-	-	1	1	-	-	-	-	
	Sub Boring	Ø10(3/8")	-	-	-	-	-	-	-	-	1	1	1	1
		Ø12(1/2")	-	-	-	-	-	-	-	-	1	1	1	1
		Ø16(5/8")	-	-	-	-	-	-	-	-	1	1	1	1
Ø20(3/4")		-	-	-	-	-	-	-	-	1	1	1	1	
Drill	MT2	1	1	-	-	1	1	1	1	1	-	1	-	
	MT3	1	1	1	1	1	1	1	1	1	1	1	1	
	MT4	-	-	1	1	1	1	1	1	-	1	-	1	
	MT5	-	-	-	-	1	1	1	1	-	-	-	-	

NV Series - Vertical Machining Center Machine Construction

Direct Drive Spindle

High-performance, directly coupled spindle, allows high-speed processing with low vibration and noise, increase machining accuracy and quality.

ATC Magazine

Holds up to 30 tools as standard to cover a wide range of tools selection ensure flexible machining conditions. Tool magazine service door in the front of the machine for easier, faster and more convenient access.



24

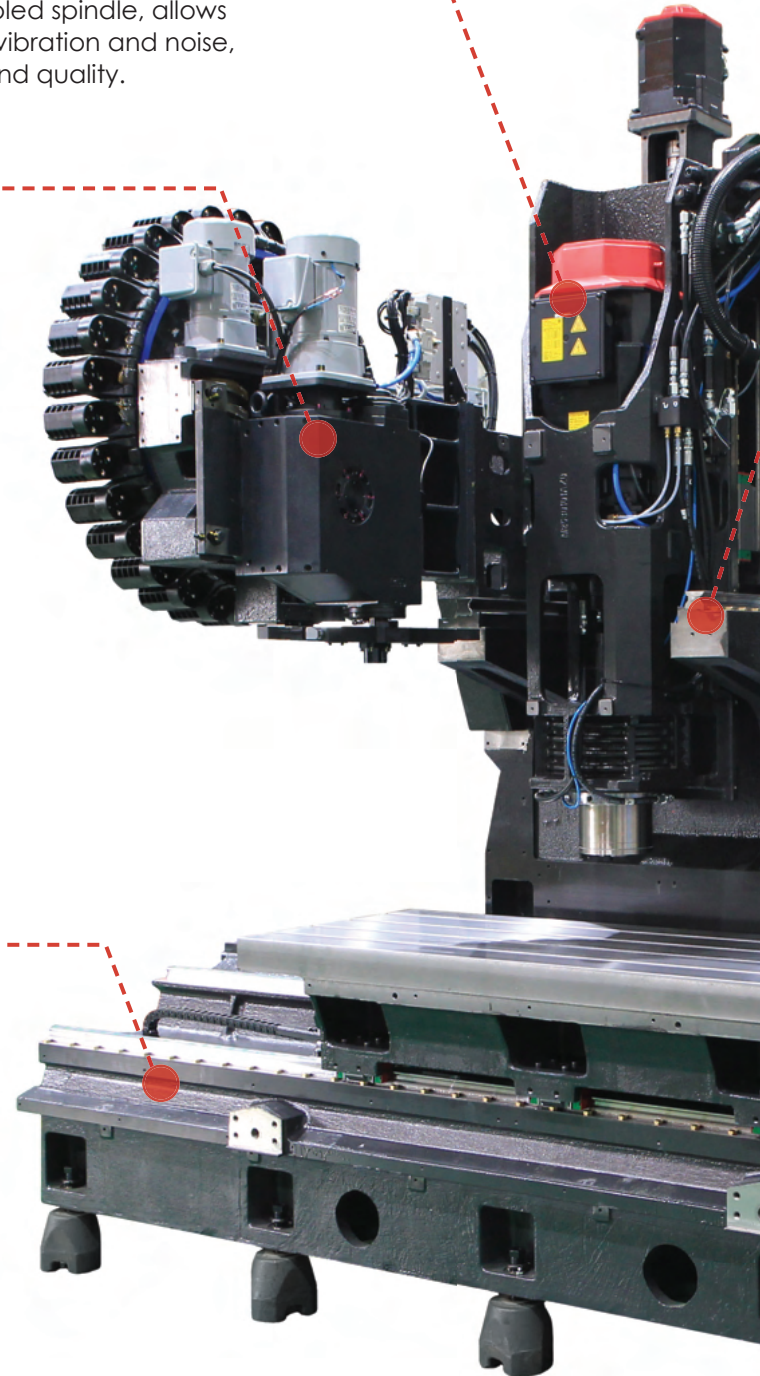

Bed

Slant bed design allowing chips generated during machining to fall directly to chip conveyor without the need for installing internal screw conveyor. Such design enables superior chip dispose out of the machine, less noise and require less maintenance compared to machines that equip with internal screw conveyors.

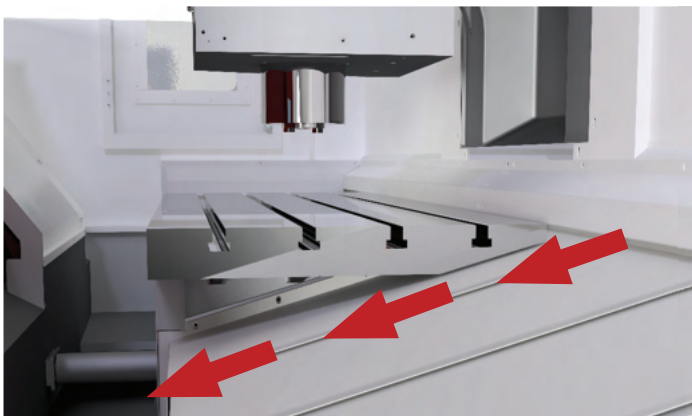

Y-Axis Structure

By mounting a saddle on the upper part of the column which has extended casting support structure for Y-axis, the over-hang issue is eliminated, positioning accuracy and machining quality are improved.

Wide Column Design

Design for extra wide column base and increased width of the contact surface between the column and the bed, improve vibration absorption ability and enhance machine stability and rigidity.

Table

No stacking axis for table, the table only travels as X-axis, allowing better machining stability. Wider workpiece mounting area compared to competitive machines within the same floor space. High rigid roller type LM guideways are applied for all the axis feed, ensure high rigidity, high accuracy and speed of axis movement and also improve load capacity.
6 LM blocks for X-axis

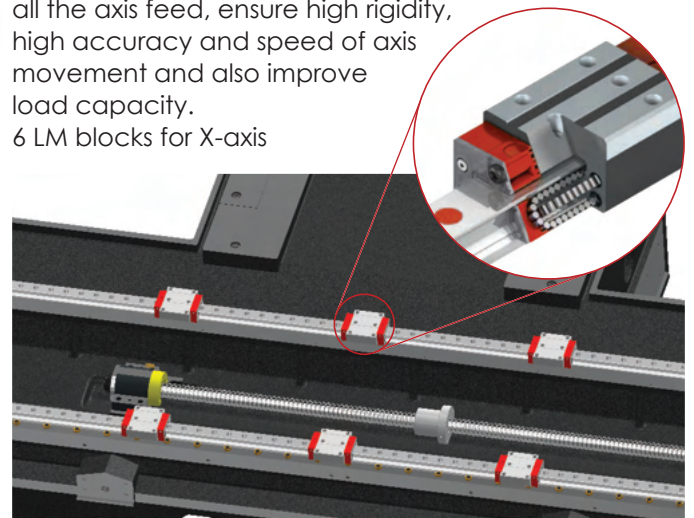

NV 5500L 12,000 RPM, BT40/CAT40, Ram type Column

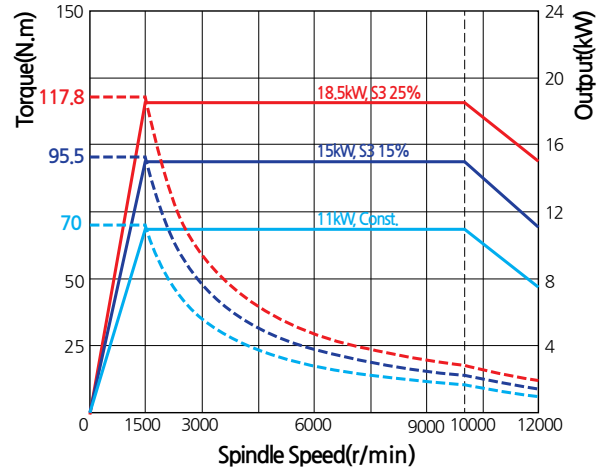
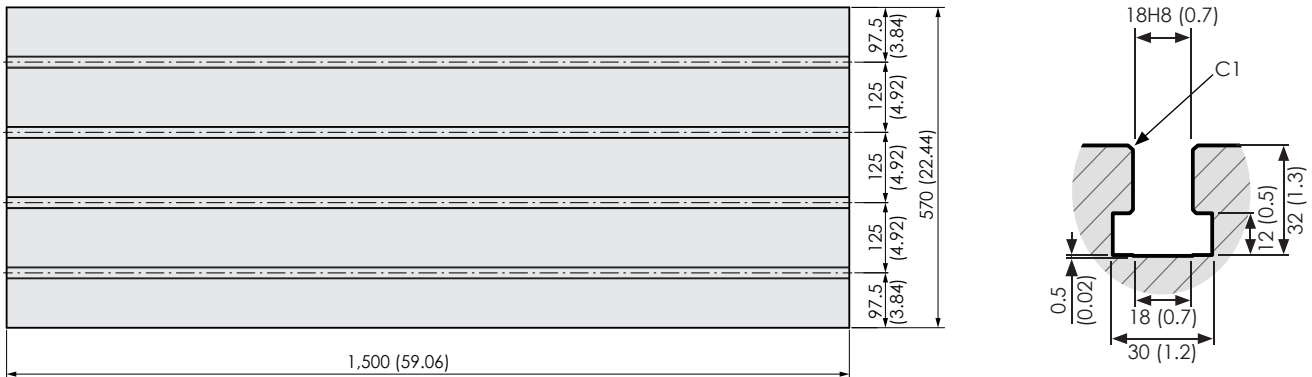

Table Dimensions

Unit: mm(inch)



NV 5500L

Machine Dimensions

Unit: mm(inch)

NV 5500L

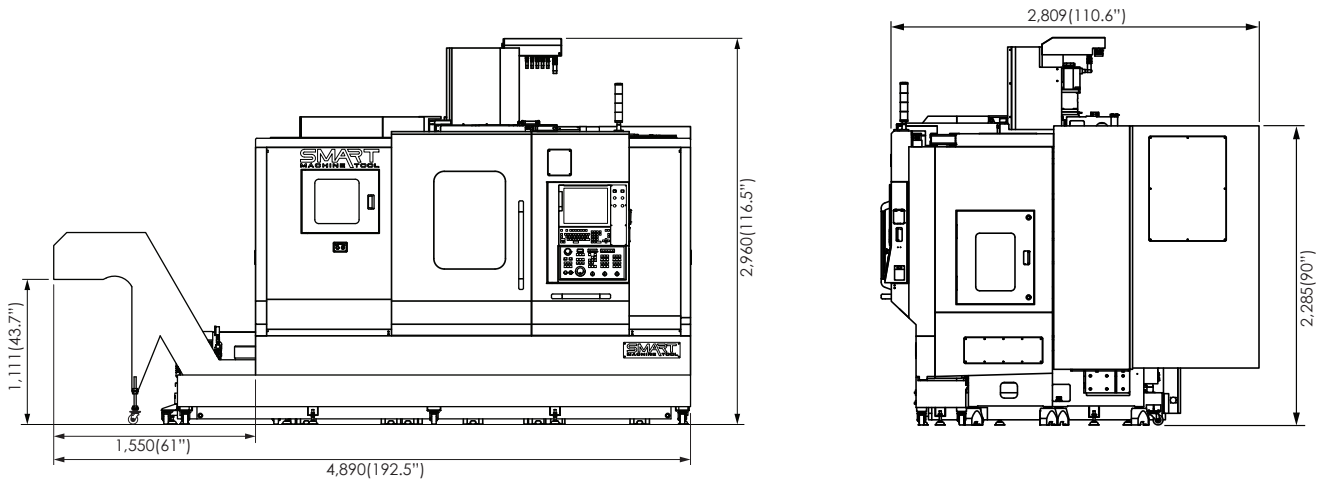

Machine Specifications

DESCRIPTION		NV 5500L	
FEED	Travel Distance (X/Y/Z)	mm(inch) 1,350/570/510(53.15/22.44/20.08)	
	Rapid Traverse Rate (X/Y/Z)	m/min(ipm) 36/36/30(1,417/1,417/1,181)	
	Distance From Spindle Nose to Table Top	mm(inch) 130~640(5.12~25.2)	
	Slide Type	- LM Roller Guide	
TABLE	Table Size	mm(inch) 1,500 x 570(59.06 x 22.44)	
	Table Loading Capacity	kg(lb) 1,000(2,204.62)	
	T Slot (WxP / No. of Slots)	mm(inch) 18H8xP125(0.71x4.92) - 4 ea	
SPINDLE	Taper	- ISO #40	
	Max. Spindle Speed	rpm 12,000	
	Spindle Output (Cont./Max)	kW(Hp) 11/18.5(14.8/24.8)	
	Max. Spindle Torque	N.m(ft.lbs) 117.8(86.9)	
ATC	Type of Tool Shank	- BT 40 [CAT 40]	
	Tool Storage Capacity	ea 30 [40]	
	Max. Tool Diameter	Continuous	mm(inch) ø80(3.15)
		Without Adjacent Tools	mm(inch) ø125(4.92)
	Max. Tool length	mm(inch) 300(11.81)	
	Max. Tool Weight	kg(lb) 8(17.64)	
	Method of Tool Selection	- Memory Random	
Tool Changing Time (Tool to Tool/Chip to Chip)	sec 1.3/3.7		
POWER SUPPLY	Electric Power Supply	kVA 40	
MACHINE DIMENSION	Height	mm(inch) 2,960(116.54)	
	Length	mm(inch) 2,809(110.59)	
	Width	mm(inch) 4,890(192.52)	
	Weight	kg(lb) 6,565(14,473)	
Control	NC System	- Fanuc 0i-MF	

• Figures in inches are converted from metric measurements.
 • Design and specifications are subject to change without notice.

[] : Option

Standard Accessories

- Direct drive spindle
- 30 ea ATC magazine storage
- Head coolant 1.1kW
- Splash guard with side coolant tank
- Portable MPG
- Manual/Part list
- Tool/Work box
- Door interlock
- Work light (LED lamp)
- Leveling blocks

Optional Accessories

- Through spindle coolant (TSC)
- Chip conveyor
- Oil skimmer
- Renishaw optical receiver (with GUI)
- Bed flushing
- Coolant gun

NC Unit Specifications / FANUC Series

● : Standard ○ : Option

	ITEM	Specification	0i-TF Plus	0i-MF Plus
Controlled axis	Controlled axes	X,Z / X,Z,C / X,Z,Y,C / X,Z,Y,B,C / X,Z,Y,B,C,A	2/3/4/5/6 Axis	3 Axis (X,Y,Z)
	Additional control axes	5 axes (Max.)	-	○
	Max. simultaneously controlled axis		4	4
	Least command increment	0.001mm / 0.0001"	●	●
Operation functions	Pulse handle feed	X1, X10, X100	●	●
	Feedrate per minute	0i-TF: G98 / 0i-MF: G94	●	●
	Feedrate per revolution	0i-TF: G99 / 0i-MF: G95	●	●
Interpolation functions	Linear interpolation	G01	●	●
	Circular interpolation	G02, G03	●	●
	Dwell	G04	●	●
	Polar coordinate interpolation	G12.1, G13.1	●	-
	Cylindrical interpolation	G07.1	●	●
	Helical interpolation		○	●
	Fine surface machining		-	●
	Variable lead thread cutting	G34	●	-
	Continuous threading		●	●
	Reference position return	G28	●	●
Reference position return check	G27	●	●	
Feed function	Rapid traverse rate override	F0%, 25%, 50%, 100%	●	●
	Feedrate override	0 ~ 200%	●	●
	AI contour control II	200 blocks	○	●
Spindle function	Spindle orientation		●	●
	Rigid tapping		●	●
	Arbitrary speed threading		○	○
Program input	Absolute/incremental programming		●	●
	Inch/metric conversion	G20 / G21	●	●
	Program restart		●	●
	Retraction for rigid tapping		○	●
	Max. programmable dimension	±999999.999mm/±99999.9999	●	●
	M function	M3 digit	●	●
	Custom macro		●	●
	Canned cycle for drilling		●	●
	Direct drawing dimension programming		●	-
	Programmable data input	G10	●	●
	Optional block skip		●	●
Workpiece coordinate system	G52 ~ G59	●	●	
Number of registerable programs		1000EA	1000EA	
Setting and display	Alarm & Operator history display		●	●
	Run hour and parts count display		●	●
	Display spindle & servo overload		●	●
	Self-diagnosis function		●	●
	Extended part program editing		●	●
	Display screen		15" Touch panel	15" Touch panel
Others	Memory card and USB interface		●	●
	Embedded ethernet		●	●
	Part program storage size	2 Mbyte (5120m)	●	●
	Manual guide <i>i</i>		●	●
	iHMI		●	●



SMART Machine Tool Korea / R&D center / Factory

115-28, Techno valley 1-ro, Jillye-myeon, Gimhae-si,
Gyeongsangnam-do, Republic of Korea
TEL : +82-55-342-7972 | FAX : +82-55-342-7970
E-mail : smtk@smtkor.com
www.smtkor.com

SMART Machine Tool America

N25W23287 Paul Rd, Pewaukee, WI 53072, USA
TEL : 1-855-637-3320
FAX : 1-262-521-1244
www.smartmachinetool.com